



FIOH  
notified by the Ministry of Social Affairs and Health  
and identified under 0403 grants

# EC TYPE EXAMINATION CERTIFICATE

12212LMS01rev10

for electrostatic dissipative protective clothing  
against heat and flame and thermal effects of electric arc  
as defined in EN 1149-5:2008, EN ISO 11612:2015,

A1+A2 B2 C2 F2,

and IEC 61482-2:2009 class 1 (4 kA)

**Multi-Layer Anti-Static Protective Clothing**

**Coveralls 602, 604, 605, 73102**

**Parkas 622, 624, 684, 686**

**Jackets 623, 629**

**Bib'n braces 641, 642, 644**

Red Wing Shoe Company Inc.

Minnesota, USA

These products comply with Directive 89/686/EEC,  
as amended

Helsinki, 16 October 2017  
Expiry date: 15 October 2022

Minna Torenius  
Specialist

Erja Tammela  
Senior Specialist



## 1. Applicant

Red Wing Shoe Company Inc.  
314 Main Street  
Red Wing  
55066 Minnesota  
USA

## 2. Description and identification of the product

Type: Electrostatic dissipative protective clothing against heat and flame, and thermal effects of electric arc as defined in EN 1149-5:2008, EN ISO 11612:2015 and IEC 61482-2:2009

EN ISO 11612: Performance levels A1+A2 B2 C2 F2  
IEC 61482-2: Class 1 (4 kA)

Name: Multi-Layer Anti-static Protective Clothing  
Coveralls 602, 604, 605, 73102  
Parkas 622, 624, 684, 686  
Jackets 623, 629  
Bib'n braces 641, 642, 644

Description: Garments can be made of the following alternative outer materials:

- Quality 00: Art# 4531, 93% Nomex, 5% Kevlar, 2% P140, 153 g/m<sup>2</sup> (Westex by Milliken, USA)
- Quality 01: Art# 6531, 93% Nomex, 5% Kevlar, 2% P-140, 203 g/m<sup>2</sup> (Westex by Milliken, USA)
- Quality 11: Art# VRE129 Flashguard, 54% Modacrylic, 35% CO, 10% Aramid, 1% carbon fibre, 195 g/m<sup>2</sup> (Kurabo, Japan)
- Quality 11P: Art# VRE129-P (permethrin treated) Flashguard, 54% Modacrylic, 35% CO, 10% Aramid, 1% carbon fibre, 195 g/m<sup>2</sup> (Kurabo, Japan)
- Quality 12: Art# BRE71042 Flashguard, 54% Modacrylic, 45% C, 1% carbon fibre, 295 g/m<sup>2</sup> (Kurab, Japan)
- Quality 15: Art# 502251, 98% CO, 2% Carbon, Twill, 220 g/m<sup>2</sup> (Daletec AS, Norway)
- Quality 19: Art# 502551, 98% CO, 2% Carbon, 250 g/m<sup>2</sup> (Daletec AS, Norway)
- Quality 21/Quality 11:  
Art# Flashguard TM VRE130 5.8/6.5, 48% Tencel, 39% MAC, 12% para-aramid, 1% carbon, Twill, 220 g/m<sup>2</sup> (Westex by Milliken, USA) or  
Art# Flashguard TM 5.8/6.5 (872251), 48% Tencel, 39% MAC, 12% para-aramid, 1% carbon, Twill, 220 g/m<sup>2</sup>, with and without permethrin treatment (Daletec C/O, Sapphire Finishing Mills, Pakistan) Quality 29: Art# 642881, 74% CO, 24% PES, 2% Carbon, 290 g/m<sup>2</sup> (Daletec AS, Norway)
- Quality 08/Quality 22: Art# Flashguard TM (872951), 48% Tencel, 39% MAC, 12% para-aramid, 1% carbon, Twill, 290 g/m<sup>2</sup> (Daletec C/O, Sapphire Finishing Mills, Pakistan)
- Quality 30: Art# 603581, 99% CO, 1% Negastat, Satin, 350 g/m<sup>2</sup> (Daletec AS, Norway) or Art# 503551, 98% CO, 2% Carbon, Satin, 350 g/m<sup>2</sup> (Daletec AS, Norway).

Garments are insulated with a quilted lining and optionally with PU membrane, 90 g/m<sup>2</sup>. Zippers used are YKK Polyester Coil Zippers.



Optional wadding materials:

- Meida, 100% PES, 150 g and 200 g with scrim
- 3M Thinsulate, 150 g and 200 g with scrim (3M, Minnesota, USA)

Optional inner lining materials:

- Art# 101731, 100% CO, 170 g/m<sup>2</sup> (Daletec AS, Norway)
- Art# ZAE001, 100% CO, 170 g/m<sup>2</sup> (Shenzhen Tecron Safety Co. Ltd., China)
- Art# F.R21\*21\*108\*58\*57/58", 100% CO, 205 g/m<sup>2</sup> (Xinxiang Xinxing Special Fabric Co. Ltd., China)

Cuffing material is Miraflex knitted cuffing material, PES/WO (Miraflex, UK) or Modastatic knit single jersey, 60% MAC/38% CO/2% antistatic fiber, 200 g/m<sup>2</sup>. Elastic bands are supplied by Alge Elastic GmbH., Austria.

Garments can be provided with the following alternative retroreflective materials:

- Loxy art. 9801 Silver (Loxy AS, Norway)
- Loxy art. 9808 Trim yellow/silver/yellow (Loxy AS, Norway)
- 3M Scotchlite 9687 Trim yellow/silver/yellow (3M, Minnesota, USA).

Representative in Europe: Red Wing Shoe BV, Van Diemenstraat 272, NL-1013 CR Amsterdam, the Netherlands

Pictures of the standard patterns and specific styles are shown in Appendix 2. The style number comprises of 5 digits including the pattern number followed by the quality number.

### 3. Adequacy and validity of the technical documentation

The documentation supplied by the applicant is listed in Appendix 1. The technical documentation is considered adequate and valid. Materials of the products have been tested in accordance with harmonized European standards EN 1149-5:2008, EN ISO 11612:2015 and IEC 61482-1-2:2007 by accredited testing laboratories. The models of the products supplied by the applicant conform to the technical documentation.

### 4. Compliance with basic health and safety requirements

The products and the technical documentation relating to them comply with the relevant basic health and safety requirements stated in Directive 89/686/EEC Annex II as amended, last amended by 96/58/EC.

Note: Any modification in design, materials, or in the technical documentation, carried out on these type examined products must be brought to the attention of FIOH.

Appendix 1. Technical documentation

Appendix 2. Pictures of the different standard patterns and specific styles

End of EC type examination certificate 12212LMS01rev10.



**Technical documentation regarding EC type examination certificate  
12212LMS01rev10**

Product name: Multi-Layer Anti-Static Protective Clothing  
Applicant: Red Wing Shoe Company Inc., 314 Main Street, Red Wing, 55066 Minnesota, USA

<i>Item of technical documentation</i>	<i>Document identification</i>	<i>Assessment</i>
1. Application for the EC type examination	2012-02-12 2013-07-16 (Pattern 629) 2014-07-08 (Qualities 16, 21, 22, Style 76654) 2014-10-07 (Quality 29) 2015-07-24 (Quality 19) 2015-12-21 (Quality 11P) 2016-05-05 2016-10-12 2017-07-12 (ZAE001) Update request, 2017-08-18 2017-10-09 (Quality 08/22)	
2. Product drawing, construction, and material list	Garment specifications	Products are identified and described, materials are specified
3. Compliance with Directive 89/686/EEC relevant basic requirements	The compliance assessment is based on reports mentioned below items 3.1-3.38	
3.1 FIOH assessment of relevant Directive basic requirements	2017-10-16	The applied harmonised standards EN ISO 13688:2013, EN 1149-5:2008 and EN ISO 11612:2015 support the relevant requirements
3.2 FIOH test report	No. 28530T01, 2008-12-298 No. 10724T01rev1, 2011-06-30 No. 163633T01rev1, 2011-06-30 Quality 00, Art# 4531 Quality 01, Art# 6531	Materials meets the requirements of EN ISO 11612:2015, A1+A2 B1 C1
3.3 Aitex test report	No. 2011EP0258, 2011-05-31 Quality 00, Art# 4531 No. 2011EP0269, 2011-05-20 Quality 01, Art# 6531	Materials meet the requirements of IEC 61482-2:2009 class 1 (4 kA)
3.4 FIOH test report	No. 28530T01, 2008-12-298 Quality 00, Art# 4531) Quality 01, Art# 6531	Materials meet the requirements of EN 1149-5:2008)
3.5 FIOH test report	No. 163633T01rev1, 2011-06-30 Assemblies of Quality 00, Art# 4531 and Quality 01, Art# 6531, with PU membrane, wadding G200 and inner lining 170 g/m <sup>2</sup>	Material assemblies meet the requirements of EN ISO 11612:2015, A1+A2 B2 C2 F3
3.6 FIOH test report	No. 10507T01rev1, 2011-02-16 No. 163632T01, 2011-04-29 Quality 11, Art# Flashguard	Material meets the requirements of EN ISO 11612:2015, A1+A2 B1 C1, and of EN 1149-5:2008
3.7 FIOH test report	No. 241737T01, 2014-01-03 Quality 11P, Art# VRE129-P Flashguard (permethrin treated)	Material meets the requirements of EN ISO 11612:2015 for limited flame spread A1, and EN 1149-5:2008
3.8 FIOH test report	No. 27383T01, 2007-09-18 No. 27383T04, 2008-02-07 No. 10723T01, 2011-02-04 No. 163632T02rev, 2011-12-23 No. 163632T01, 2011-04-29 Quality 12, Art# Flashguard, BRE71042	Material meets the requirements of EN ISO 11612:2015, A1+A2 B1 C1 F1, and EN 1149-5:2008



3.9 Aitex test report	No. 2011EP0266, 2011-05-20 Quality 11, Art# Flashguard No. 2011EP0267, 2011-05-20 Quality 12, Art# Flashguard	Materials meet the requirements of IEC 61482-2:2009 class 1 (4 kA)
3.10 FIOH test report	No. 163632T01, 2011-04-29 Assemblies of Quality 11, Art# VRE129 and Quality 12, Art# BRE71042, with PU membrane, waddings G200 and G150 and inner lining 170 g/m <sup>2</sup>	Material assemblies meet the requirements of EN ISO 11612:2015, A1+A2 B2 C2, with lining G200 F3, with lining G150 F2
3.11 West Yorkshire Materials Testing Service test report	No. 63452 (Amended), 2014-02-03 No. 63452-01, 2014-03-13 No. 63452, 2014-03-24 Quality 15, Art# 502251/53	Material meets the requirements of EN ISO 11612:2015, A1 A2 B1 C1, EN 1149-5:2008 and IEC 61482- 2:2009 class 1 (4 kA)
3.12 West Yorkshire Materials Testing Service test report	No. 65500, 2014-07-09 No. 64876-1, 2014-07-09 No. 66726-02, 2014-10-24 No. 69476, 2015-03-25 Quality 19, Art# 502551/53	Material meets the requirements of EN ISO 11612:2015, A1 B1 C1, EN 1149-5:2008 and IEC 61482-2:2009 class 1 (4 kA)
3.13 FIOH test report	No. 256457T01, 2014-08-22 Quality 21/11, Art#Flashguard TM VRE130 5.8/6.5	Material meets the requirements of EN ISO 11612:2015, A1 A2 B1 C1, EN 1149-5:2008 and IEC 61482- 2:2009 class 1 (4 kA)
3.14 West Yorkshire Materials Testing Service test report	No. 76393 (Amended) & 76394 (Amended), 2016-09-08 No. 76393 (Amended) & 76394-03 (Amended), 2016-09-08 No. 76393-04, 2016-07-26 Quality 21/11, Art# 87225/53/68, Red Wing Flashguard TM	Material meets the requirements of EN ISO 11612:2015, A1 A2 B1 C1, EN 1149-5:2008 and IEC 61482-2:2009 class 1 (4 kA)
3.15 West Yorkshire Materials Testing Service test report	No. 84188_03, 2017-06-27 No. 90109 (Amended), 2017-10-15 Quality 8/22, Art# 872951 Red Wing Flashguard 8.5 oz TM	Material meets the requirements of EN ISO 11612:2015, A1 A2 B1 C1 E1 and EN 1149-5:2008
3.16 Kinetrics test report	No. K-352002-1709B04 R00, 2017-09-28 Quality 8/22, Art# 872951 Red Wing Flashguard 8.5 oz TM	Material meets the requirements of IEC 61482-2:2009 class 1 (4 kA)
3.17 West Yorkshire Materials test report	No. 57165, 2013-03-19 No. 57165-02, 2013-04-15 Quality 29, Art# 642881	Materials meet the requirements of EN ISO 11612:2015, A1 B1 C1 and EN 1149-5:2008
3.18 FIOH test report	No. 364104T01, 2017-10-02 Quality 29, Art# 642881	Material meets the requirements of EN ISO 11612:2015 for limited flame spread A2
3.19 STFI test report	Certificate of Test No. Z 4071/09- 5166/09, 2009-03-27 Quality 29, Art# 642881	Materials meet the requirements of IEC 61482-2:2009 class 1 (4 kA)
3.20 STFI test report	Z 4156/09-5280/09, 2009-06-24 Quality 30, Art# 603581	Material meets the requirements of EN ISO 11612:2015, A1 B1 C1 F1, and requirements of IEC 61482- 2:2009 class 1 (4 kA)
3.21 FIOH test report	No. 163631T01rev1, 2011-06-30 Quality 30, Art# 603581	Material meets the requirements of EN ISO 11612:2015 for limited flame spread A2
3.22 West Yorkshire Materials Testing Service test report	No. 56633, 2013-03-01 No. 60220, 2013-05-03 No. 63454, 2014-02-12 No. 56633-04, 2013-04-17 Quality 30, Art# 503551	Material meets the requirements of EN ISO 11612:2015, A1 A2 B1 C1 E1 F1, EN 1149-5:2008 and IEC 61482-2:2009 class 1 (4 kA)





3.23 FIOH test report	No. 163631T01rev1, 2011-06-30 Assembly of Quality 30, Art# 603581, with wadding G150 and inner lining 170 g/m <sup>2</sup>	Material assembly meets the requirements of EN ISO 11612:2015, A1+A2 B2 C2 F2
3.24 West Yorkshire Materials Testing Service test report	No. 36291, 2008-08-22 Art# 101731	Inner lining material meets the requirement of EN ISO 14116:2015, limited flame spread index 3
3.25 Intertek test report	No. GZHT01797896, 2017-07-12 No. GZHT01786926, 2017-06-28 100% cotton, Plain weave woven fabric, 170 g/m <sup>2</sup> , Art# ZAE001	Inner lining material meets the requirement of EN ISO 14116:2015, limited flame spread index 3
3.26 SGS test report	No. QD1104529-1/TX, 2011-04-19 Woven 100% cotton F.R21*21*108*58*57"/58"	Inner lining material meets the requirement of EN ISO 14116:2015 for limited flame spread index 3
3.27 Aitex test report	No. 2011EP0535, 2011-06-22 Coverall 604 in quality 30	Garment meets the requirements of IEC 61482-2:2009 class 1 (4 kA). Result can be applied to the garments with the same type of quality and accessories
3.28 FIOH test report	No. 176124T01, 2011-09-27 FR Antistatic Modacrylic Cotton Knit	Ventilation opening material meets the requirements of EN ISO 11612:2015, A1 B1 C1, and EN 1149-5:2008
3.29 Intertek test report	No. 397264/07, 2007-04-16 Miraflex black knitted cuffing fabric	Material meets the requirements of EN ISO 14116:2015 for limited flame spread index 3 (without pretreatment)
3.30 ÖTI test report	No. 65519, 2011-03-21 Elastic tapes	Elastic tapes meet the requirements of EN ISO 11612:2015 for limited flame spread and heat resistance 260°C
3.31 FIOH test certificate	No. 325539T01rev1, 2016-11-11 LOXY 9801	Retroreflective material meets the requirements of EN ISO 20471:2013, EN ISO 11612:2015 for limited flame spread and heat resistance and EN 1149-5:2008
3.32 Satra test report	Ref: SPC0218279/1338/4, 2013-09-30 Loxy 9808 Trim	Retroreflective material meets the requirements of EN ISO 20471:2013 EN ISO 14116:2015 index 3, and EN ISO 11612:2015 for heat resistance
3.33 FIOH test report	No. 300432T01, 2015-03-17 3M Scotchlite 9687 Fire Coat Trim Fluorescent yellow-silver-fluorescent yellow	Retroreflective material meets the requirements of EN ISO 20471:2013 and EN ISO 11612:2015 for limited flame spread A1 and heat resistance
3.34 FIOH test report	No. 163633T01rev1, 2011-06-30 Seam, chain stitch with overlocking and two stitchings	Seam meets the requirements of EN ISO 11612:2015 for limited flame spread A1 A2, and seam strength
3.35 FIOH test report	No. 362772T01, 2017-09-04 YKK Polyester Coil Zipper on fabrics Q11 & 21 and Q15	Zipper meets the requirements of EN ISO 11612:2015 for limited flame spread A1 and heat resistance
3.36 STFI test report	No. 2015 1373.4, 2015-08-03 Plastic snap button type DPV 300/15	Plastic snap buttons meet the requirements of EN ISO 11612:2015 for heat resistance and limited flame spread A1
3.37 Draft information sheet	User information	Document meets the requirements of the Directive, EN ISO 13688:2013, EN 1149-5:2008, EN ISO 11612:2015 and IEC 61482- 2:2009



3.38 Product markings	Drafts of markings in the garment specifications	Markings meet the requirements of EN ISO 13688:2013, EN 1149-5:2008, EN ISO 11612:2015 and IEC 61482-2:2009
4. Description of the production quality system and related product control and test facilities	ISO 9001:2008 Certificate No. 43276, 2012-05-21	Agreement with FIOH on the EC quality control system for the final product (PPE category III product)



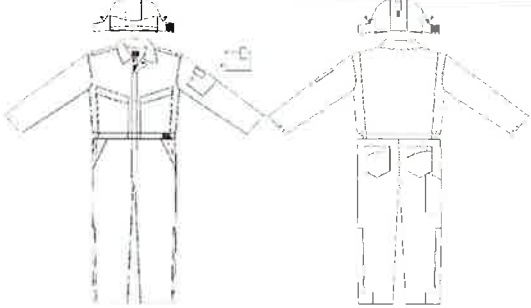
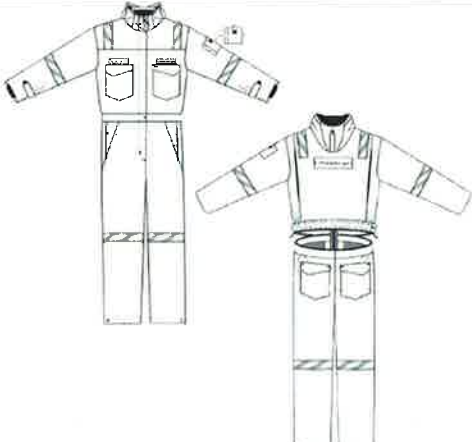
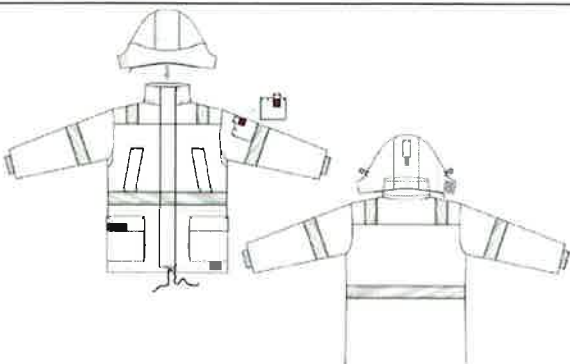
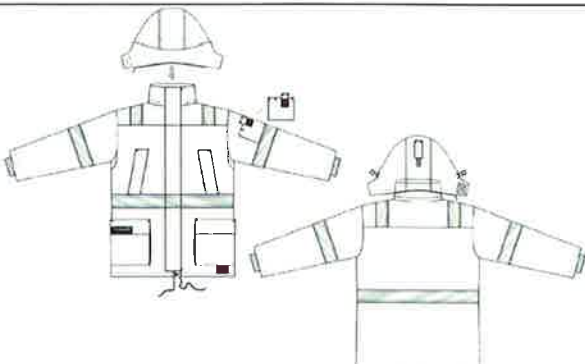

**Pictures of the different basic styles**

Style RW 602 FR Lined Coverall	Style RW 604 FR Lined Coverall
	
Style RW 605 FR Lined Coverall	Style RW 73102 Women's FR Lined Coverall
	
Style RW 622 FR Parka	Style RW 624 FR Parka
	



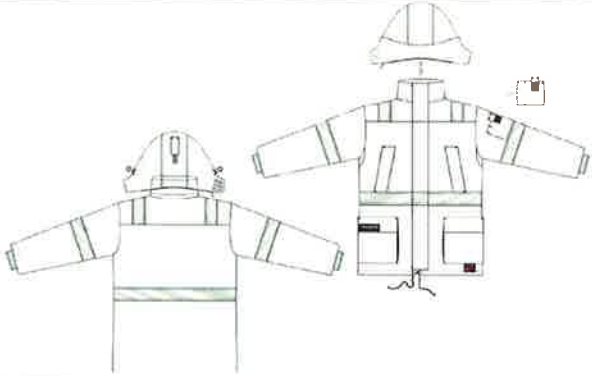
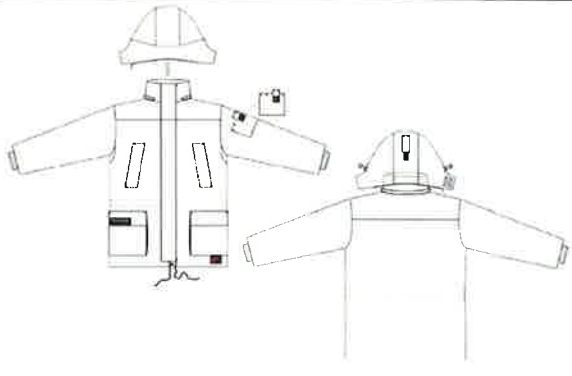

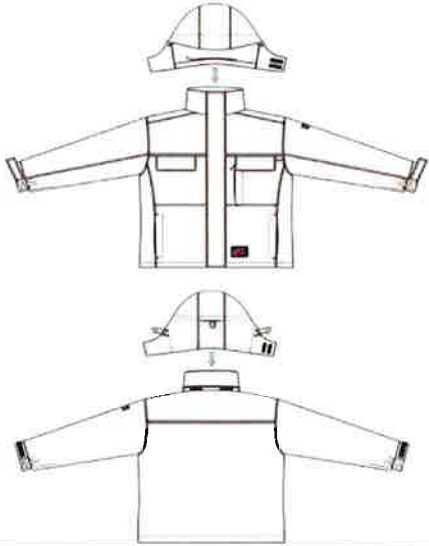
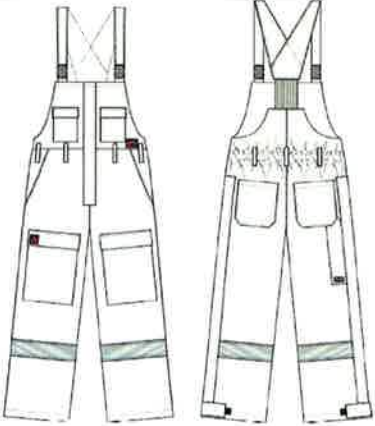
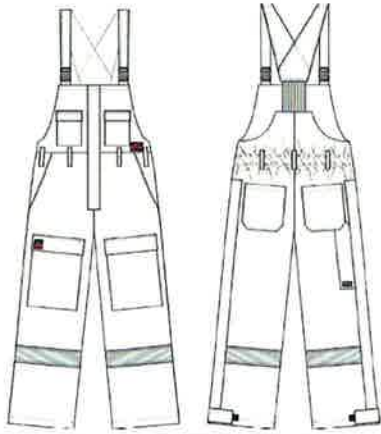
Style RW 684 FR Parka	Style RW 686 FR Parka
	
Style RW 623 FR Jacket	Style RW 629 FR Jacket
	
Style RW 641 FR Winter Bib'n Brace	Style RW 642 FR Winter Bib'n Brace
	



Style RW 644 FR Winter Bib'n Brace	
